

GCSE Maths – Geometry and Measures

Surface Area of 3D Shapes

Worksheet

NOTES



SOLUTIONS



This worksheet will show you how to work out different types of surface area of 3D shapes questions. Each section contains a **worked example**, a **question with hints** and then **questions for you to work through** on your own.

This work by [PMT Education](https://www.pmt.education) is licensed under [CC BY-NC-ND 4.0](https://creativecommons.org/licenses/by-nc-nd/4.0/)



Section A

Worked Example

Find the surface area of the following cube:

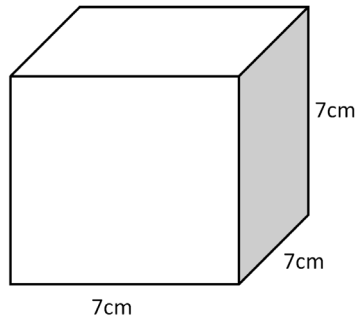

Step 1: Find the area of one face.

$$\text{Area of face} = \text{length} \times \text{width} = 7 \times 7 = 49 \text{ cm}^2$$

Step 2: Multiply the area of one face by 6 to find the total surface area.

Since all faces of a cube are the same, we can simply multiply the area of one side by 6 to find the total surface area:

$$\text{Surface area} = 49 \times 6 = \mathbf{294 \text{ cm}^2}$$

Remember that the final answer is in units² because it is a measure of area.

Guided Example

Find the surface area of the cube.

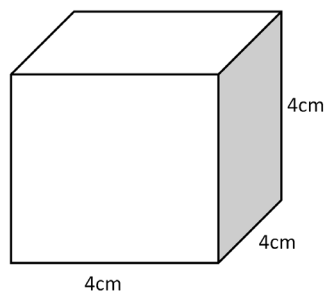

Step 1: Find the area of one face.

Step 2: Multiply the area of one face by 6 to find the total surface area.



Now it's your turn!

If you get stuck, look back at the worked and guided examples.

1. Calculate the surface area of the following cube:

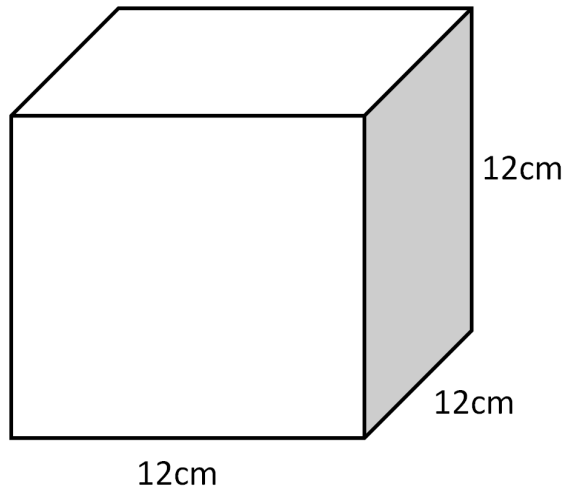

2. Calculate the length of each side of a cube if its total surface area is 433.5 cm^2 .
3. The length of a cube measures 5.5 cm . What is the surface area of the cube?



Section B

Worked Example

Find the surface area of the cuboid:

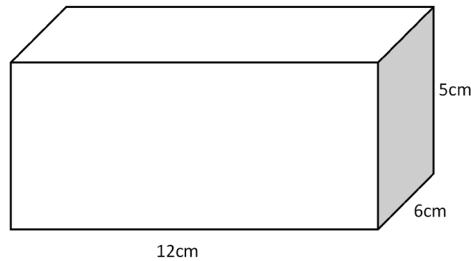

Step 1: Find the area of three different faces.

The opposite faces of a cuboid are identical. Therefore, we only need to find the area of one face of each pair. This means we need to calculate the area of three different faces. We can find the area of the front-facing, right-facing and upwards-facing sides:

$$\text{Front face area} = 12 \times 5 = 60 \text{ cm}^2$$

$$\text{Right face area} = 6 \times 5 = 30 \text{ cm}^2$$

$$\text{Top face area} = 12 \times 6 = 72 \text{ cm}^2$$

Step 2: Add together the areas of the three different faces, then double to find the total surface area.

$$\text{Area of the three faces} = 60 + 30 + 72 = 162 \text{ cm}^2$$

$$\text{Total surface area} = 162 \times 2 = \mathbf{324 \text{ cm}^2}$$

Guided Example

Find the surface area of the cuboid:



Step 1: Find the area of three different faces.

Step 2: Add together the areas of the three different faces, then double to find the total surface area.



Now it's your turn!

If you get stuck, look back at the worked and guided examples.

4. Calculate the following:

a) The surface area of this cuboid

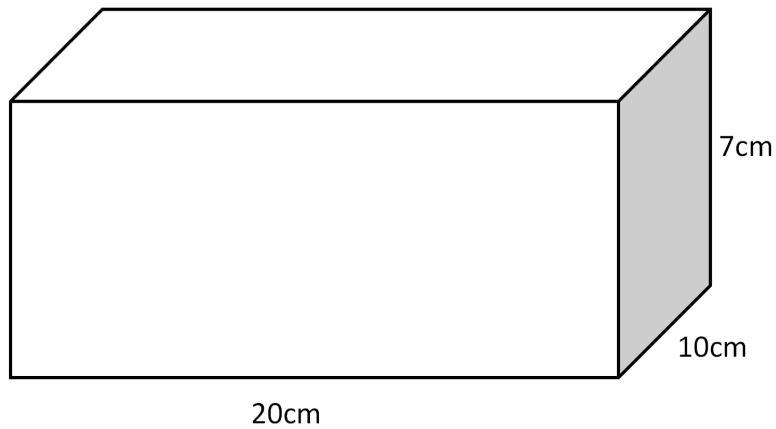

b) The surface area of this cuboid

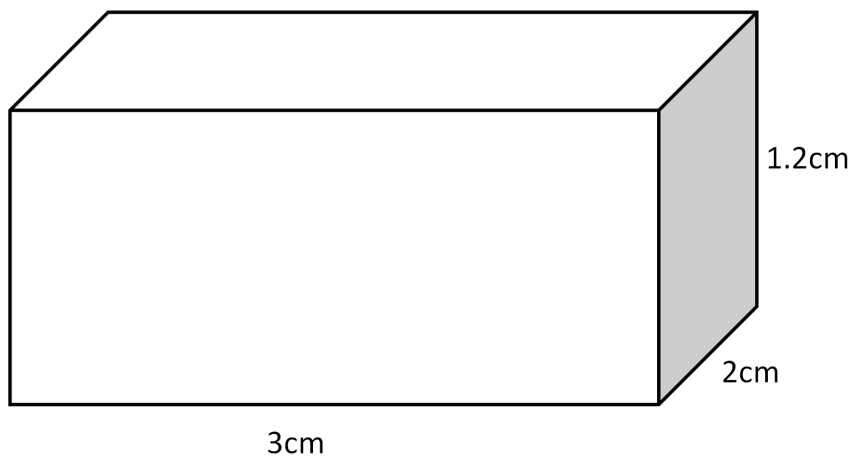

Section C

Worked Example

Find the surface area of the following cylinder:

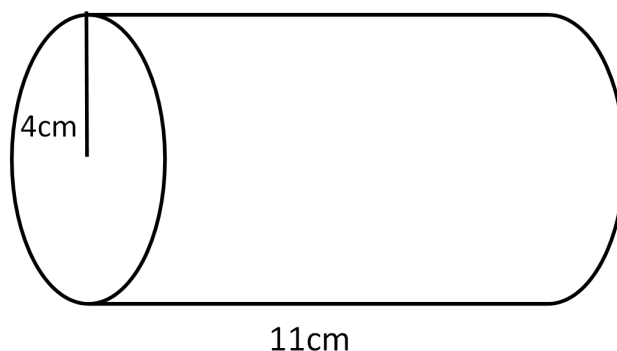

Step 1: Find the area of the two circular faces using the formula for the area of a circle.

The formula for the area of a circle is

$$\text{Area} = \pi \times r^2,$$

where r is the radius of the circle.

As there are two circular faces, we double the area of one to find the total area of the two circular faces:

$$\text{Area of one face} = \pi \times 4^2 = 50.265 \text{ cm}^2$$

$$\text{Area of two faces} = 2 \times 50.265 \text{ cm}^2 = 100.531 \text{ cm}^2$$

Step 2: Find the area of the curved face in the middle by multiplying the length of cylinder by the circumference of the circular face.

We can imagine the curved face in the middle as a rectangle wrapped around, with its length as the length of the cylinder and its width as the circumference of the circle.

$$\text{Circumference of circular face} = \pi \times \text{diameter} = \pi \times 8 = 25.133 \text{ cm}$$

$$\text{Curved face area} = \text{cylinder length} \times \text{face circumference} = 11 \times 25.133 = 276.46 \text{ cm}^2$$

Step 3: Add together the areas of the circular faces and curved face to find the total surface area.

$$\text{Surface area} = \text{Area of curved surface} + \text{Area of faces}$$

$$= 276.46 + 100.531 = \mathbf{376.99 \text{ cm}^2}$$



Guided Example

Find the surface area of the following cylinder:

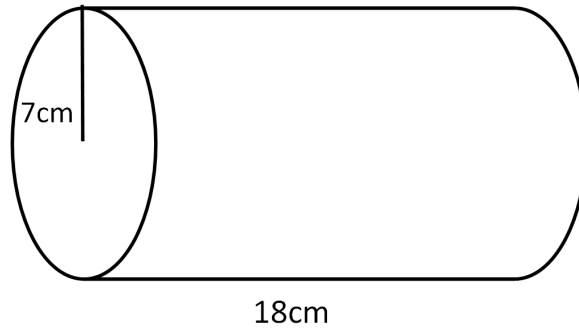

Step 1: Find the area of the two circular faces using the formula for the area of a circle.

Step 2: Find the area of the curved face in the middle by multiplying the length of cylinder by the circumference of the circular face.

Step 3: Add together the areas of the circular faces and curved face to find the total surface area.



Now it's your turn!

If you get stuck, look back at the worked and guided examples.

5. Calculate the following:

a) The surface area of this cylinder

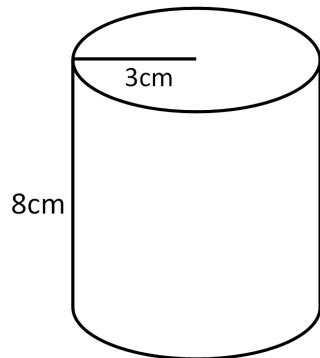

b) The surface area of this cylinder

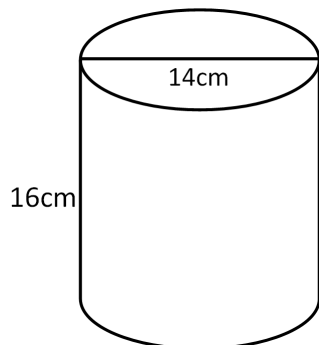

c) The height of this cylinder if its total surface area is 471.24 cm^2

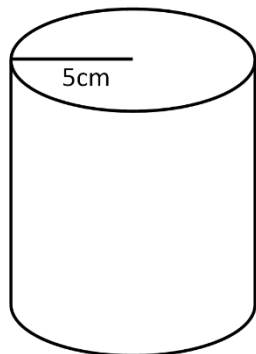

Section D

Worked Example

Find the surface area of the following pyramid:

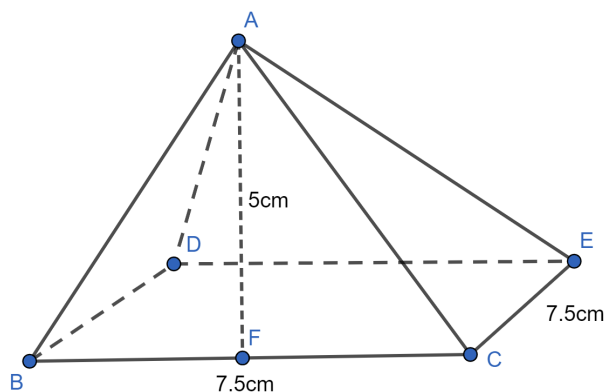

Step 1: Find the area of the base of the pyramid.

The base for this pyramid is a square, so we find the area by multiplying the length by the width:

$$\text{Area of base} = 7.5 \times 7.5 = 56.25 \text{ cm}^2$$

Step 2: As this is a square-based pyramid, all triangular faces are the same. Find the area of one of the triangular faces, then multiply by the number of triangular faces.

All the triangular faces have the same base and height, so we simply find the area of one and multiply by 4 (as there are 4 triangular faces here).

$$\text{Area of one triangular face} = \frac{\text{Base} \times \text{Height}}{2} = \frac{7.5 \times 5}{2} = 18.75 \text{ cm}^2$$

$$\text{Total area of triangular faces} = 4 \times 18.75 = 75 \text{ cm}^2$$

Remember that the triangular faces may not always be identical – if we had a rectangle-based pyramid, or sometimes even a triangular-based pyramid, the bases of the triangular sides may not be the same. The heights will be the same, as each face has the same termination at the tip. In this case, we have to calculate the area of each triangular face individually and then add them together.

Step 3: Add together the areas of the base and triangular faces to find the total surface area.

$$\text{Total surface area} = \text{Area of base} + \text{Area of triangular faces}$$

$$= 56.25 + 75 = \mathbf{131.25 \text{ cm}^2}$$



Guided Example

Find the surface area of the following pyramid:

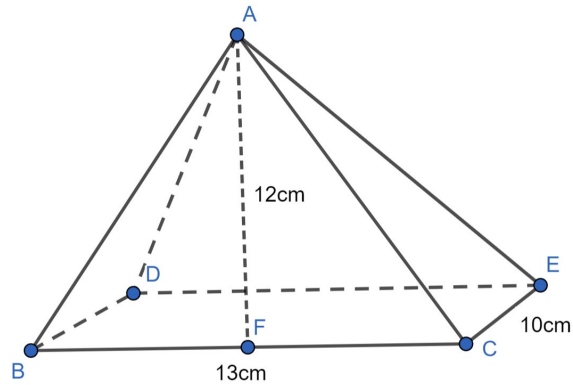

Step 1: Find the area of the base.

Step 2: As this is a rectangle-based pyramid, the base lengths of each triangular face are not the same. Find the area of the triangular faces individually using the base lengths and height given.

Step 3: Add together the areas of the base and triangular faces to find the total surface area.



Now it's your turn!

If you get stuck, look back at the worked and guided examples.

6. Calculate the following:

- a) The surface area of this pyramid where all faces are the same, including the base:

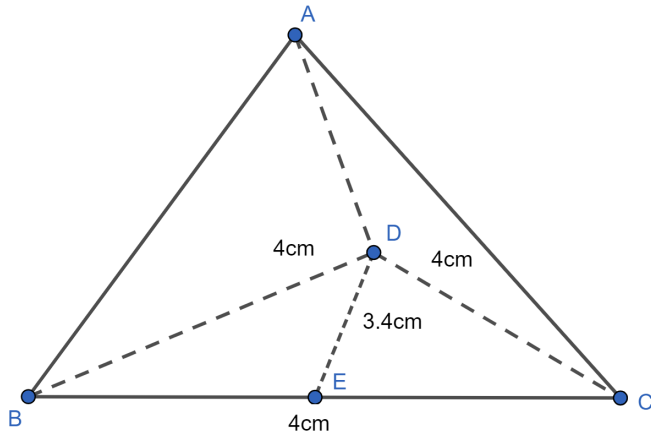

- b) The surface area of this pyramid

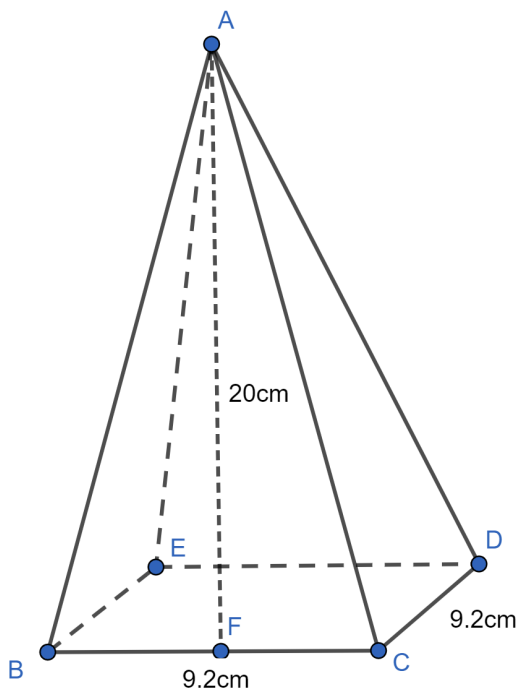

Section E

Worked Example

Find the surface area of the following cone:

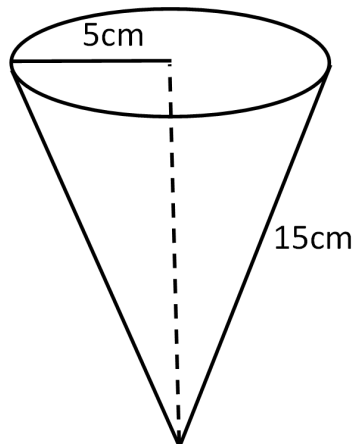

Step 1: Find the area of the circular face.

The formula for the area of a circle is

$$\text{Area} = \pi \times r^2,$$

where r is the radius of the circle.

$$\text{Area of circular face} = \pi \times 5^2 = 78.54 \text{ cm}^2$$

Step 2: Find the area of the curved face using the formula πrl .

Remember to use the sloped height of the cone, not the perpendicular height!

$$\text{Area of curved face} = \pi rl = \pi \times 5 \times 15 = 235.62 \text{ cm}^2$$

Step 3: Add together the areas of the circular face and curved face to find the total surface area.

$$\begin{aligned} \text{Total surface area} &= \text{Area of circular face} + \text{Area of curved face} \\ &= 78.54 + 235.62 = \mathbf{314.16 \text{ cm}^2} \end{aligned}$$



Guided Example

Find the surface area of the following cone:

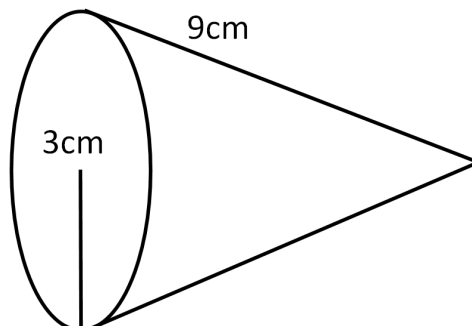

Step 1: Find the area of the circular face.

Step 2: Find the area of the curved face using the formula πrl .

Step 3: Add together the areas of the circular face and curved face to find the total surface area.



Now it's your turn!

If you get stuck, look back at the worked and guided examples.

7. Calculate the following:

a) The surface area of this cone

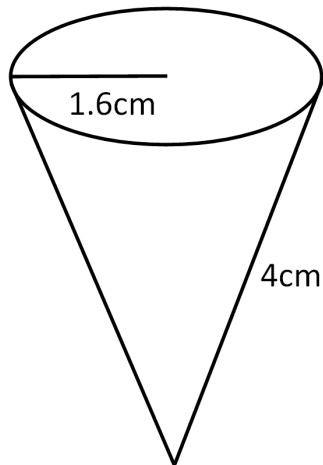

b) The length of this cone if the total surface area is 339.29 cm^2

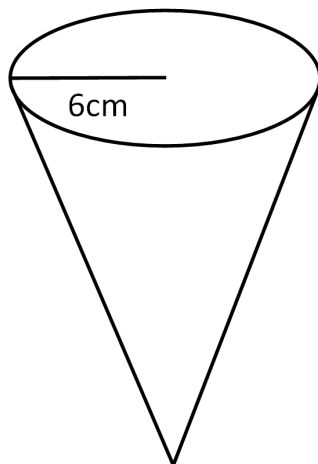

Section F

Worked Example

Find the surface area of the sphere. The following diagram represents a cross-section of the sphere:

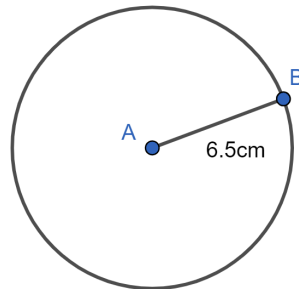

Step 1: Calculate the surface area using the formula for the surface area of a sphere.

$$\text{Surface area} = 4\pi r^2$$

$$\text{Surface area} = 4 \times \pi \times 6.5^2 = 530.93 \text{ cm}^2$$

Guided Example

Find the surface area of the sphere. The following diagram represents a cross-section of the sphere:

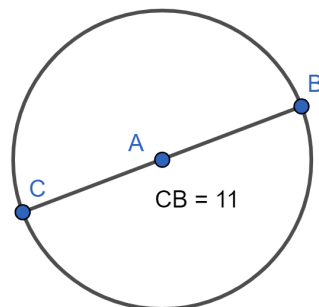

Step 1: Calculate the surface area using the formula for the surface area of a sphere.



Now it's your turn!

If you get stuck, look back at the worked and guided examples.

8. Calculate the following:

a) The surface area of this sphere

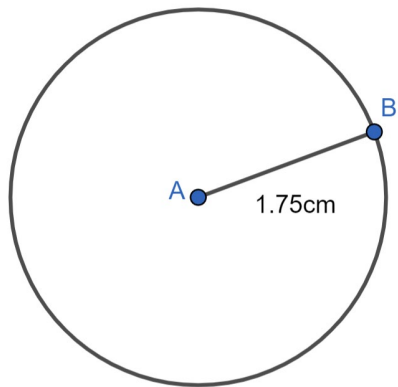

b) The surface area of this sphere

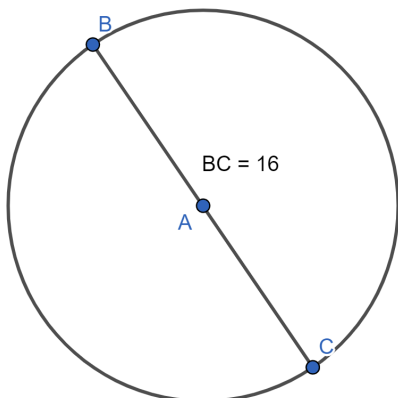

c) The radius of a sphere if its surface area is 1017.88 mm^2



Section G

Worked Example

Find the surface area of the following composite shape:

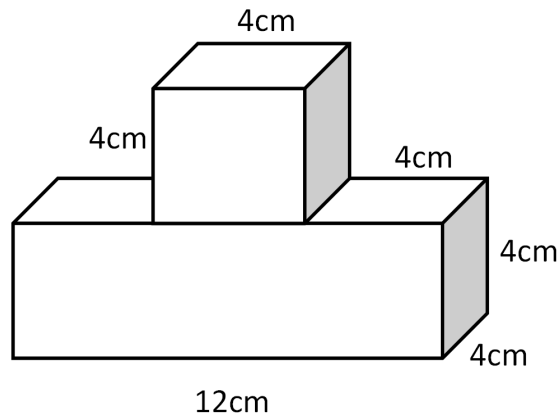

Step 1: Work out which sides are facing outwards (these ones count as the total surface area).

For the cube at the top, all sides except the bottom side are facing outward, so 5 faces are counted.

For the cuboid, 5 full faces are facing outwards, and part of the top face. We can calculate how much of the top face is covered by the cube.

Step 2: Work out the surface area of the sides facing outwards.

For the cuboid:

$$\text{Front face area} = 12 \times 4 = 48 \text{ cm}^2$$

$$\text{Front and back face area} = 48 \times 2 = \mathbf{96 \text{ cm}^2}$$

$$\text{Right face area} = 4 \times 4 = 16 \text{ cm}^2$$

$$\text{Right and left face area} = 16 \times 2 = \mathbf{32 \text{ cm}^2}$$

$$\text{Bottom face area} = 12 \times 4 = \mathbf{48 \text{ cm}^2}$$

$$\text{Top face area} = (12 - \text{length of cube}) \times 4 = 8 \times 4 = \mathbf{32 \text{ cm}^2}$$

$$\mathbf{\text{Total surface area}} = 96 + 32 + 48 + 32 = 208 \text{ cm}^2$$

For the cube:

$$\text{One face area} = 4 \times 4 = 16 \text{ cm}^2$$

$$\text{Area of 5 faces} = 16 \times 5 = \mathbf{80 \text{ cm}^2}$$

Step 3: Add together the surface area of each shape.

$$\text{Surface area} = \text{Cube surface area contribution} + \text{cuboid surface area contribution}$$

$$= 80 + 208 = \mathbf{288 \text{ cm}^2}$$



Guided Example

Find the surface area of the following composite shape:

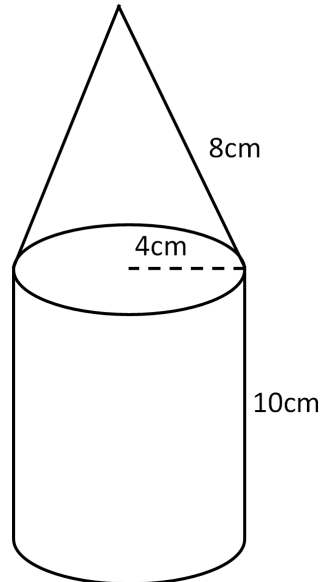

Step 1: Work out which faces are facing outwards. These faces count towards the total surface area.

Step 2: Work out the surface area of the sides facing outwards.

Step 3: Find the total surface area.



Now it's your turn!

If you get stuck, look back at the worked and guided examples.

9. Calculate the following:

a) The surface area of this composite shape

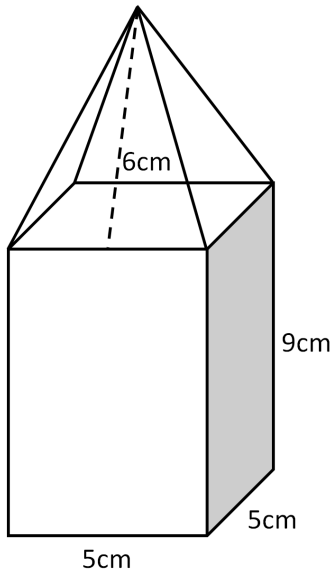

b) The area of this composite shape

